



Scanning Tour of Innovative Vehicle Towing Through Crane

Umeshwari Sahare¹
sahareumeshwari@gmail.com

Ashwini Khobragade²
ashwinikhobragade760@gmail.com

Shivani Mirase³
shivanimirase@gmail.com

Gayatri Bansod⁴
bansodgayatri2@gmail.com

Divya Khadse⁵
dk9527553716@gmail.com

Pradip Balbudhe⁶
Pb6143@gmail.com

Suryodaya College of
Engineering and Technology,
Nagpur, India.

Abstract— The Prospective system is basically a vehiculate system construct to auditor and track the activity of the drag crane which belongs to the Mumbai traffic police. The system is deployed inside the automobile whose location is to be determined and pursued real time. The main detached of the arrangement is to keep a watch on activities of the crane driver, provide a direct access of the goods to the officials of the MTP, count the number of vehicles towed per day and keep a watch on damaged to the tracked vehicle. The system uses the GPS machineries that is one of the most accepted ways to track vehicle. A Raspberry pi is recycled to manage the GPS and GPRS module and gets the geographical co-ordinates at regular intervals. The raspberry pi is recycled to broadcast the data and store the collection of goods. The officials at MTP will be continuously able to track the vehicle on demand. This documents presents some data to vehiculate arrangement and actions on constructive implementation.

Index terms: GPS, MTP, Raspberry pi, Vehicle tracking, GSM.

I. INTRODUCTION

A. Background

The parking of vehicles and space related problems are very common. There are 2.4 million automobiles in Mumbai. Some shipping agency display that Mumbai's automobile frequency 1,417 per km was crosswise to 34 cities and community in the welfare. The more number of vehicles, the more space they require. Here it needs to track, sense, control and monitor. MTP needs to auditor the towing crane activities by mechanisms of Geo-location, camera, monitoring hydraulic pumps and identifying loading and unloading with accurate load. It can spectacle the area of all automobiles in actual time, so certainly they can constitute the conventional evidence properly.

B. Perspective System

This modern automation is worn to modify together regularly either by several hault to the organization and deliever venue evidence to the supervise band. We come up with custom mobile DVR uniqually construct and executed

at Mumbai. The perspective system is an intention to solve the majority of problems related to detect the vehicle.

The system tells us the locale of the crane when the automobile is dragged. One of the features is the system can tell us the details about the vehicle including its number and in which area it was being parked.

C. Overview

The system that has been planned can provide a cheap solution to the above mentioned problems of the existing systems. This is improved security systems for vehicles. The planed system comes with certain additional features that are already present in DVRs that is images of the dragged automobile and the actual time video while towing the vehicle will be convenient to the database and the website. The platform used for making the system is Raspberry pi. The pi uses its own default operating system and the coding languages that is worn here is python. Some other computing platforms that can be recycled here are Arduino, Banana pi, Intel Galileo board. But Pi provides us with a very fast option and has the provision of more storage than all of the above mentioned developmental boards.

Raspberry Pi is familiar function, occasionally with Linux executive, and capacity to rush the curriculum. Python is recycled for coding in our system. Other languages that are subtend to the catcall are Java script, Java, HTML5 and J-query. The languages such as html and PHP are used other than python are used for website development. This article discusses the component of the sensors used, the languages and the SIM 0808.SIM808 factor is an entire Quadruplet chain, GSM/GPRS members which associated Global Positioning System automation for planetoid exploration. The SIM 808 works fully upon the AT+ commands.

II. OBJECTIVE

Special leading example of vehicle tracking is from the cab company UBER.UBER doesn't use standalone GPS systems fitted in the cars to follow the vehicles. UBER introduced a GPS based car navigation and vehiculation are supported by the UBER mobile application.

Whether the cab company retain minor cars or a less hundred cars, you demand GPS following for taxi cabs to guide your speedy perfectly.

Through robust, yet simple to understand reports, you will be able to review the performance of every driver, route manager, and vehicle in your company.

III. PERSPECTIVE METHODOLOGY

The proposed system works in three different modes. They are monitoring phase, detection phase and the data upload phase. In the monitoring phase the system works as simple location monitoring system as in the simple cars and other vehicles, whose purpose is the security of the vehicle. The IP camera remains on the video recording mode. The video is stored in the local storage of the system which is present on board. The monitoring phase is always on. The GPS location is always traced and the log is stored in the local storage.

The network camera is in the video recording mode. The recorded video is stored in the local storage. When the ignition is on the system goes in the detection phase. In the

detection phase the system searches for the input from the hydraulic oil pressure sensor. When the pressure is detected, the system checks if the pressure is greater than 180 units. If the pressure is less than 180 psi then system keeps looking for the input from the pressure sensor and is still in the detection phase. When the pressure detected is more than 180 units, the network camera starts capturing images of the vehicle towed by the crane.

The captured data is sent to the web server. The web server uploads the data to the database. We can access the data through the site that is made available by us for the Mumbai traffic police. To make the system with above functionality we have to follow the critical path methodology. This approach involves the identification of problem and the problem statement is defined by the end user or the client. Then a solution is proposed and the steps and algorithms are involved to get the desired results. The steps involve the designing of the hardware, programming for the interface and the software platform. We used Raspberry pi as the platform.

Second step is to get the power supplies for our system that we require to run our system. There are dedicated power supplies for the GPS system that is the SIM 808 and the network camera. The ignition provides the supply for the hydraulic oil pressure sensor. Another step is to interface the pressure sensor to the Pi and program it so that it can get the analog input directly and send an interrupt to the ongoing process and take the required action. Then the network camera is connected to the raspberry pi by the LAN cable. The network camera could be able to work in two different modes.

The GPS receiver receives the coordinate from the satellite which is then send to the GSM tower by the GSM modem. The coordinate is then sent to a computer via internet where it is stored in the database for displaying the location on Google map. The user can also see the location of the vehicle in a mobile phone, when the user sends an SMS to the GSM modem in the vehicle, the GSM modem send another SMS back to the user with the coordinates of the location of the vehicle along with a Google map link.

The flowchart given in the figure1 describes the working principle of how the system should work.

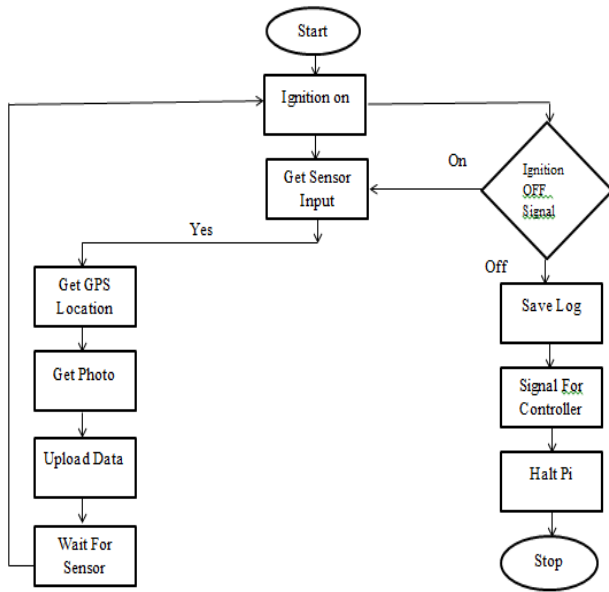

Figure 1: Flow Chart

IV. IMPLEMENTATION

Figure 2 is of circuit diagram of the proposed system. Vehicle tracking device is made up with Raspberry Pi, SIM 808 module including GPS and GSM antenna. The core part of tracking system is microcontroller raspberry pi. For monitoring the location of the vehicle on the map, we had developed a web application. For storing the location data, a text file had been used. We had also developed a mobile application to view the location of vehicle in a mobile device by using Android Studio.

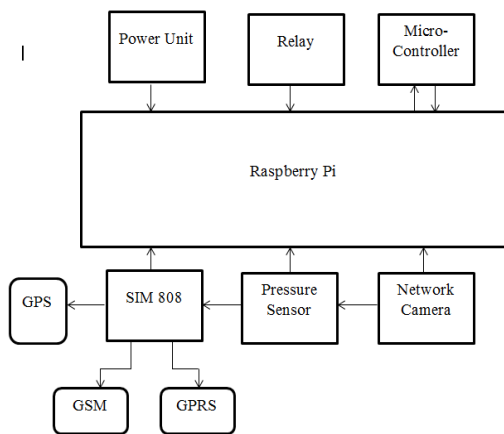

Figure 2: Block Diagram

Device initialization process may take up to 1 minute to worm up and calculate the accurate position. SIM 808 requires 2A peak current. So, external power supply like 12V-2A battery is used to provide the power. GPS antenna and GSM antenna are connected to the port of SIM 808 module.

SIM 808 module is run by using AT command in the program of Pi. Initially, the network registration is done by using AT+CREG and set Access Point Name (APN), user name and password. After that turn on the GPS power supply using the command CGPSPWR and current GPS location information can be gotten using AT+CGPSINF command. After getting the data of vehicle’s location we have used two methods to send the data to the user end. If the user or owner of the vehicle sends a SMS to the mobile number which SIM card is used into the SIM 808 module, it will continuously send the SMS to the user’s mobile of the current location. Another way, by using HTTP request to web server the data has been sent. For sending SMS, AT+CMGS command is used in the program and AT+CMGR command is used to read the SMS which has been sent from the user. For setting the configuration of GPRS, AT+SAPBR command has been used.

In this project, we built a vehicle tracking device which will be imbedded into a vehicle and monitoring that vehicle in real time. In tracking device, GPS receiver receives the data or information mainly latitude and longitude of the particular vehicle from the satellite which information is transferred over mobile phone via Short.

V. CONCLUSIONS

Project aim and objective have been covered during project implementation. Proposed design fulfils the aim and objective of the project and implemented for recommending vehicle area. The officials at the MTP were able to follow the crane on demand continuously. Hardware and Software required for this plan is also being research thoroughly. All the hardware has been tested before implementation and python language is use for controlling the hardware in mobile unit which was

uploaded to Raspberry Pi. The future scope is to cut the rate of the system.

REFERENCES

- [1] Vaibhav Hans, Parminder Singh nSethi and Jatin Kinra, “An approach to IOT base car parking and skepticism system on cloud”, Universal convenience on verdant gauge and Internet of Thing(ICGIOT), Noida, October 2015.
- [2] Vinay Sagar K N and Kusuma S M, “Home Automaton and Internee-t of Things”, Foreign magazine construction and Technology(IRJET) e-ISSN:2395 – 0056, Content: 02 Issue: 03, June 2015.
- [3] Nagalakshmi T S and Nirmala L, “Automation of Automobile using IOT: A Survey”, Journal of universal Leading Engineering and Research Development (IJAERD) e-(O)-2348-4470, Content 3, Issue 4 April- 2016.
- [4] Rocky Mountain Tracking. (2013). Rocky Mountain Tracking: Main Page [Online].
- [5] Asaad M. J. Al-Hindawi, Ibraheem Talib, “Experimentally Evaluation of GPS/GSM Based System Design”, Journal of Electronic Systems, Volume 2 Number, 2 June, 2012.
- [6] Kunal Maurya , Mandeep Singh, Neelu Jain, “Real Time Vehicle Tracking System using GSM and GPS Technology- An Anti-theft Tracking System”, International Journal of Electronics and Computer Science Engineering, ISSN 2277-1956/V1N3-1103-1107.
- [7] VikramKulkarni&ViswaprakashBabu, “embedded smart car security system on face detection”, special issue of IJCCT, ISSN(Online) : 2231-0371, ISSN(Print):0975-7449, volume-3, issue-1.